



**Zimmer®
Periarticular
Distal Radial
Volar Locking
Plates Surgical
Technique**



The science of the landscape

Surgical Technique For Periarticular Distal Radial Volar Locking Plates

This surgical technique developed
in conjunction with:

Douglas P. Hanel, M.D.

Professor, Orthopaedics
and Sports Medicine
University of Washington
Seattle, Washington

Table of Contents

Introduction	2
Locking Screw Technology	3
Locking Plate Technology	3
Plate Features	3
Indications	3
Fracture Classification	4
The Three-Column Theory of Distal Radius Fracture Fixation	4
Volar Fixation of Fractures of the Distal Radius	5
Treatment Algorithm	6
Surgical Technique	8
Preoperative Preparation	8
Fracture Reduction	8
Volar Approach	8
Plate Positioning	10
Fracture Fixation	11
Implant Removal	12
Instruments and Implants	13
Ordering Information	15

Introduction

The *Zimmer* Periarticular Locking Plate System combines locking screw technology with periarticular plates to create fixed-angle constructs for use in multifragmentary fractures or where deficient bone stock or poor bone quality is encountered. The fixed-angle plate/screw device can be used in osteopenic bone and other areas where traditional screw fixation may be compromised.

The Periarticular Locking Plates will accommodate standard screws, as well as locking screws with threaded heads. When necessary, interfragmentary compression can be achieved with lag screws.

All plate configurations contain locking screw holes in the plate head and alternating locking and compression screw holes in the shaft. The locking screw holes will accept either conical or locking screws.

The distal radius plates will accept 2.4mm Locking Screws, 2.4mm Conical Screws and 1.8mm Locking Pegs in the plate head. The plate shaft will accept 2.4mm Conical Screws and 2.4mm Locking Screws in the threaded holes and 3.5mm Cortical Screws with 2.7mm head in the compression slots.

Locking Screw Technology

The heads of the locking screws contain male threads while the holes in the plates contain female threads. This allows the screw head to be threaded into the plate hole, locking the screw into the plate. This technical innovation provides the ability to create a fixed-angle construct while using familiar plating techniques.

Locking Plate Technology

By using locking screws in a bone plate, a fixed-angle construct is created. In osteopenic bone or fractures with multiple fragments, secure bone purchase with conventional screws may be compromised. Locking screws do not rely on bone/plate compression to resist patient load, but function similarly to multiple small angled blade plates. In these cases, the ability to lock screws into a fixed-angle construct is imperative.

By combining locking screw holes with compression screw holes in the shaft, the plate can be used as both a locking device and a fracture compression device. If compression is desired, it must be achieved first by inserting the standard screws in the compression screw holes before inserting any locking screws.

The locking plate design does not require compression between the plate and bone to accommodate loading. Therefore, screw thread purchase in the bone can be achieved with a thread depth less than that of traditional screws. The shallow thread profile, in turn, allows for screws with a larger core diameter to accommodate loading with improved bending and shear strength.

Plate Features

Features of the Periarticular Locking Plate include:

- Plates are precontoured to help with metaphyseal/diaphyseal reduction
- Thick-to-thin plate profiles make the plates autocontourable
- Anatomical contouring of the plates matches the shape of the distal radius
- Low plate profile facilitates fixation without impinging on soft tissue
- Plates are available in left and right configurations, in a variety of lengths

Indications

The Periarticular Locking Plate System is indicated for temporary internal fixation and stabilization of osteotomies and fractures, including:

- Comminuted fractures
- Supracondylar fractures
- Intra-articular and extra-articular condylar fractures
- Fractures in osteopenic bone
- Nonunions
- Malunions

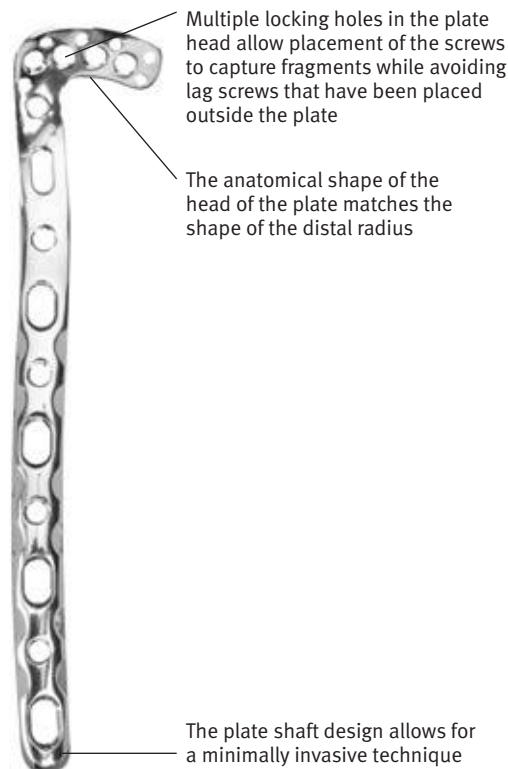

Fracture Classification

The AO classification for long bone fractures is divided into three general groups, each with three subgroups. The groups are extra-articular, partial articular, and complex articular. The subgroups reflect the degree of metaphyseal comminution.

Refer to the **AO Comprehensive Classification of Fractures of Long Bones** for more specific information.

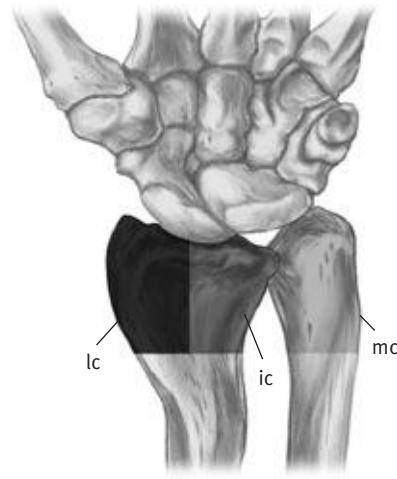

The Three-Column Theory of Distal Radius Fracture Fixation

The Three-Column theory of distal radius fracture fixation includes the following (Fig. 1):

- Lateral Column – The lateral side of the radius including the radial styloid and the scaphoid fossa
- Intermediate Column – The ulnar side of the radius, including the lunate fossa and the sigmoid notch
- Medial Column – The ulnar head, including the triangular fibrocartilage complex (TFCC) and the ulnar part of the distal radioulnar joint (DRUJ)

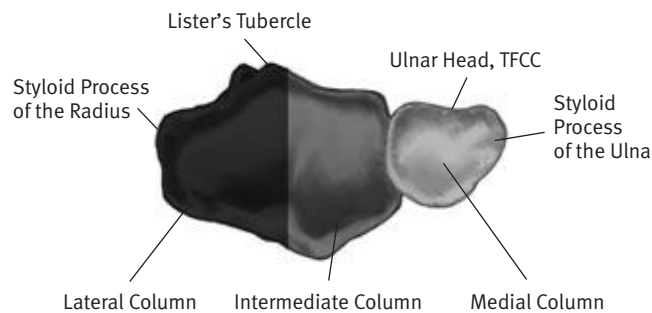
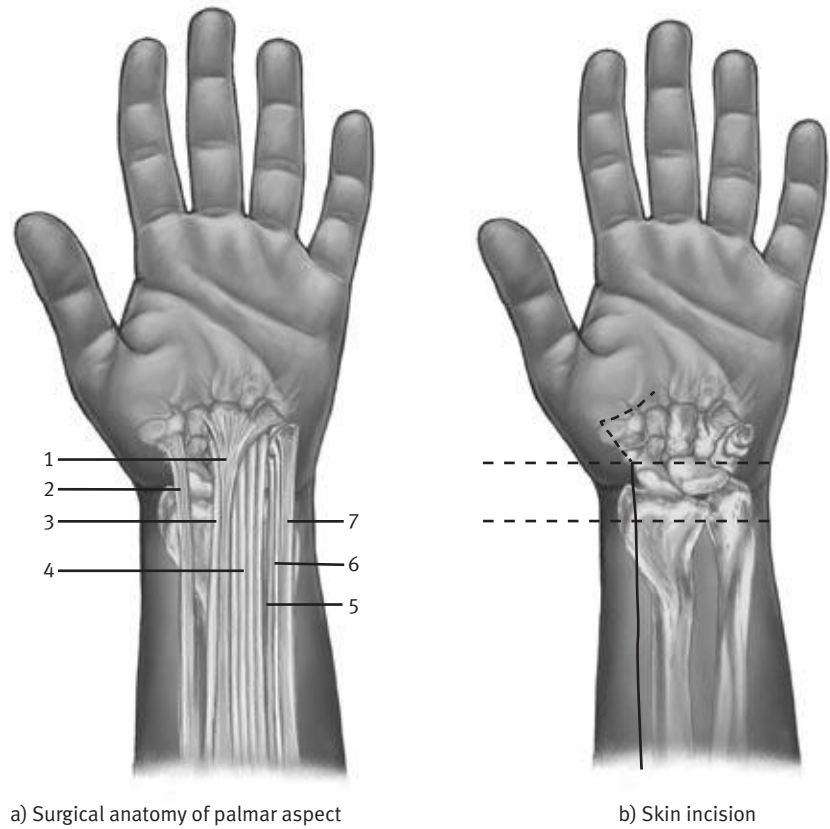

Fig. 1

Rikli DA, Regazzoni P. Fractures of the Distal End of the Radius Treated by Internal Fixation and Early Function. *J Bone Joint Surg.* 1996;78-B(4):588-9.

Volar Fixation of Fractures of the Distal Radius

A volar approach is typically used for volarly displaced fractures and may be utilized for some dorsally displaced fractures (Fig. 2).



a) Surgical anatomy of palmar aspect

b) Skin incision

1) Palmaris longus muscle, 2) Flexor carpi radialis (FCR), 3) Median nerve, 4) Flexor digitorum profundus (FDP), 5) Ulnar artery, 6) Ulnar nerve, 7) Flexor carpi ulnaris (FCU)

Fig. 2

Treatment Algorithm

Fracture of the distal radius

Non-displaced

- Plaster cast or splint and/or percutaneous pinning
- Follow-up
 - Weekly x-rays. If reduction is lost then by definition the fx is unstable and should be treated with more than cast immobilization
- Secondary displacement or metaphyseal comminution (involving more than 1/3 of the diaphysis on lateral projection)
 - Closed reduction and percutaneous pinning and/or external fixation (with or without bone graft)
 - Plate fixation
- After Care: See Postoperative Management

Displaced

Reducible

Extra-articular (AO ASIF Type A)

- Closed reduction then same as Non-Displaced Intra-articular (AO ASIF Types B and C)
- Closed reduction
 - Stable (infrequent)
 - ◇ Plaster cast or splint
 - After Care: See Postoperative Management
 - Secondary displacement
 - ◇ Closed reduction
 - Percutaneous pinning
 - Percutaneous pinning & external fixation (with or without limited open incisions and with or without bone graft)
 - Plate fixation (with or without bone graft)
 - ◇ After Care: See Postoperative Management

Irreducible/Unstable

Extra-articular

- Closed reduction and percutaneous pinning (assisted by image intensification)
- External fixation (with or without bone graft and percutaneous pinning)
- Plate fixation (with or without bone graft)

Intra-articular

- Limited open reduction, bone graft, percutaneous fixation and external fixation
- Open reduction plate fixation (volar vs dorsal, fixed angle vs conventional)

Postoperative Management

If treated by closed casting, then follow up radiographs are obtained weekly for a minimum of three weeks after injury. Radiographs are compared to the initial reduction.

If treatment is percutaneous or open, then the frequency of radiographs is predicated upon the surgeon's interpretation of fixation stability.

Initial immobilization is in a long arm splint with the wrist neutral and the forearm in supination.

Edema control and digit motion are started straight away.

Splint and cast are changed to short arm devices when the DRUJ is considered stable.

Patients often have difficulty regaining or maintaining forearm supination.

In those patients with stable DRUJ's, long arm splints with the forearm in supination and the wrist in slight extension are worn until supination is easily maintained.

External Fixators, when used, require daily pin tract care. Crusts are removed with soap and water, and the patient must keep the sites dry. Gauze or sponge bumpers are used to minimize motion about the skin pin interface.

Both radiocarpal motion and grip strength follow closely after regaining forearm and digit motion. Strengthening exercises and radiocarpal motion are not typically emphasized until after evidence of fracture healing and return of forearm and digit motion.

Surgical Technique

Preoperative Preparation

After assessing the fracture radiographically and preparing a preoperative plan, place the patient in the supine position with the hand and arm on a radiolucent hand table. Be sure that the fluoroscope can be positioned to visualize the distal radius in both the lateral and A/P views.

Fracture Reduction

It is imperative that accurate reduction of the joint be obtained prior to, and maintained during, application of the distal radius plate. The initial reduction is assisted by continuous finger trap traction in the standard horizontal upper extremity operating position and is visualized by intraoperative image intensification. Agee's reduction maneuver provides a survey of metaphyseal stability and articular incongruity. The maneuver assists in reduction, but continuous traction may interfere with the application of plates and screws, especially those implants placed volarly. To that end, provisional fixation and frequent assessment of reduction maintenance with image intensification will be required if traction is removed. Attempting to apply the radius plate without such traction risks fixing the fracture in an unreduced position and may make the sequencing of the procedure very difficult.

A closed reduction is performed in the following manner:*

1. Apply ten pounds of longitudinal traction to restore overall length. (It may even restore, but not maintain, intra-articular step off in fractures treated shortly after injury).
2. Translate the hand and radiocarpal joints volarly relative to the forearm. This will restore palmar tilt and, more importantly, will reveal unstable volar shearing fractures such as those associated with the volar medial corner of the radius in severely comminuted fractures, or those associated with the more typical shearing fractures that are often referred to as Smith-Barton fractures.
3. Slightly pronate the hand and deviate ulnarly relative to the forearm (NOT Forearm pronation relative to the elbow). This restores radial inclination and the rotatory component of fractures that result from falls onto outstretched hands.

Volar Approach

Fractures that are volarly unstable require volar stabilization. These are the fractures that involve the volar aspect of the lateral and intermediate columns. The most obvious are shearing fractures referred to with the eponym Smith/Barton, or high energy compression fractures that split the sigmoid notch in a coronal plane.

In addition, one must be aware that a rather innocuous appearing fracture that involves the volar medial corner can result in volar radiocarpal fracture dislocation if untreated.

In addition, with the recent introduction of fixed angle devices, many radius fractures that would have required dorsal support can now also be managed with volar fixation.

Exposing the Radius

Make a straight longitudinal incision directly over the Flexor Carpi Radialis (FCR). If the incision is to be extended beyond the wrist crease, then it is directed at 45 degrees radially (Fig. 3). Mobilize the FCR ulnarly and incise the floor of the FCR tendon sheath. The musculo-tendinous portion of Flexor Pollicis Longus (FPL) will be encountered and is retracted ulnarly exposing the Pronator Quadratus (PQ). Detach the fibers of the pronator quadratus from the lateral (radial) most aspect of the radius and elevate the PQ from the bony surface and retract it ulnarly. The fibers of the PQ are intimately associated with the insertion of the Brachioradialis (BR), and as such the PQ can be elevated with a slip of BR to assist with later re-approximation. In addition, if the fracture involves the area of the BR insertion then that insertion is divided, alleviating one of the major deforming forces to fracture reduction.

* Agee JM. Unstable fracture dislocations of the proximal interphalangeal joint. Treatment with the force couple splint. *Clin Orthop*. 214:101-112, 1987.

With elevation of the PQ volar lip of the radius, the volar radiocarpal ligaments will be seen distally (Fig. 3). Do not open the volar wrist capsule; this compromises vascularity of the fracture fragments and stability of the radio carpal joint. For direct visualization of the articular surface, perform a dorsal arthrotomy or arthroscopy through a dorsal wrist portal.

Articular fracture reduction

Using the interdigitation of metaphyseal fracture fragments and image intensification, the articular fracture is reduced and held in place with provisional K-wire fixation. K-wires that are essential for fracture reduction, but which interfere with placement of the volar plate, can be driven out through the dorsum of the wrist leaving 1-2mm exposed on the volar surface and 4-5mm protruding out the skin. These pins will be removed after the plate is secured.

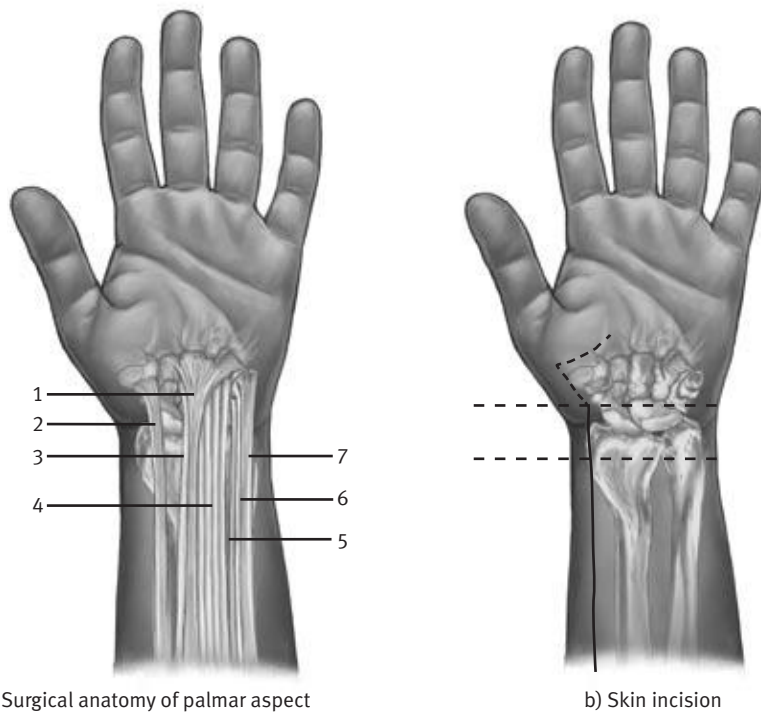

a) Surgical anatomy of palmar aspect

b) Skin incision

1) Palmaris longus muscle, 2) Flexor carpi radialis (FCR), 3) Median nerve, 4) Flexor digitorum profundus (FDP), 5) Ulnar artery, 6) Ulnar nerve, 7) Flexor carpi ulnaris (FCU)

Fig. 3

Plate Positioning

Use the appropriate Metaphyseal Jig to thread the appropriate number of Standard Cannulas into the holes in the metaphyseal portion of the plate prior to placing the plate on the bone. (Fig. 4).

Remove the Metaphyseal Jig.

Apply the appropriate length Periarticular Distal Radial Volar Locking Plate to the bone and position it in the desired location using anatomic landmarks and fluoroscopic images (Fig. 5).

Distal fracture fragment stabilization is optimized when the subchondral support lies immediately below the articular surface. In the distal radius, the articular surface is concave in more than one plane, making accurate tangential radiographic assessment difficult. **Inaccurate reduction and stabilization of the joint may cause the metaphyseal screws to penetrate the articular surface.**



Fig. 4

NOTE: The Metaphyseal Jig and Standard Cannulas **MUST** be used to ensure that the screws align properly with the threaded plate holes. Failure to use the Metaphyseal Jig and Standard Cannulas may result in cross-threading or improper seating of the screws.

A forty-five degree (45°) pronated oblique view* will effectively display the relationship between the dense subchondral bone and the support hardware to verify implant placement.

To obtain the pronated oblique view, the forearm is pronated 45° from either a PA or anteroposterior projection with the horizontal x-ray beam centered on the wrist or a vertically oriented beam and the wrist supinated 45° from full pronation.

Because the radial shaft may not be aligned with the distal fragment, the plate head should be used to determine the appropriate placement of the plate. The plate head should conform to the shape of the distal radius and be nestled into the volar ridge.

Once distal fixation is achieved, the plate/distal radius construct will be reduced to the radial shaft.



Fig. 5

WARNING: Do not contour or bend the plate at or near a threaded hole, as doing so may deform the threaded hole and cause incompatibility with the Locking Screw.

* D.W. Smith and M.H. Henry, *J Hand Surg* 2004; 29A:703-706)

While holding the plate securely in place, reduce the distal fragments by inserting 1.6mm Kirschner wires through the appropriate 1.8mm holes in the head of the plate (Fig. 6). The holes are designed to allow the wires to be angled. After inserting the first wire, check the position of the plate and, if necessary, adjust the position of the plate as necessary. Then insert additional Kirschner wires in the other 1.8mm holes in the head of the plate. The wires will help reduce the articular segment and stabilize the plate while drilling the screw holes.

Additional 1.25mm or 1.6mm Kirschner wires or screws may be placed outside the plate to help reduce or hold fracture fragments in place.



Fig. 6

Fracture Fixation

Initial Plate Fixation

NOTE: If lag screw reduction is necessary for any fragment, the lag screw must be inserted before inserting locking screws into that fragment.

Use the 1.8mm Drill Bit through the first Standard Cannula to predrill the hole for the first 2.4mm Conical Screw (Fig 7). This screw will be used to pull the plate to the bone. Use the 2.4mm/1.8mm Locking Screw Depth Gauge to determine the screw length.

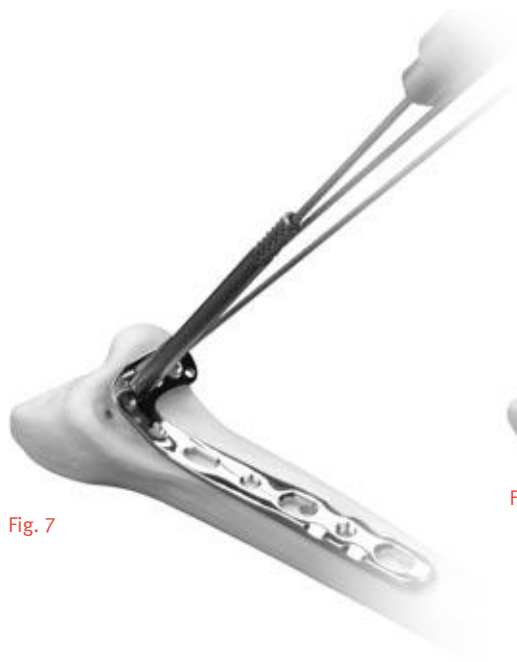

Fig. 7

Remove the Standard Cannula and insert the appropriate length 2.4mm Conical Screw into the distal radius through the plate head using the 1.5mm Hex Screwdriver (Fig 8). Follow the same procedure for additional Conical Screws. Be sure the plate is in the desired location and the Conical Screws have compressed the plate to the bone.



Fig. 8

Initial Shaft Fixation

Reduce the articular segment to the diaphysis by inserting another Kirschner wire. Prepare to insert a 2.4mm Conical Screw through one of the threaded holes or insert a 3.5mm Cortical Screw into a compression slot in the proximal portion of the shaft of the plate to help compress the plate to the surface of the bone. Predrill with the appropriate drill bit (Fig. 9).



Fig. 9

Measure for screw length using the appropriate Depth Gauge. Then, select and insert the appropriate length 2.4mm Conical Screw (Fig. 10) or 3.5mm Cortical Screw (Fig. 11). Insert the 2.4mm Conical Screw or 3.5mm Cortical Screw (Fig. 12).



Fig. 11



Fig. 10



Fig. 12

Final Fixation

Check the alignment of the shaft with A/P and lateral fluoroscopic views and insert as many additional Conical, Locking or Cortical Screws as necessary into the head and shaft of the plate.

If desired, the initial Conical Screws may be removed and replaced with Locking Screws or Locking Pegs.

Make a final check of the limb alignment and fracture reduction. Then make sure that all shaft locking screws are securely tightened. Securely tighten the distal locking screws again before closing.

Wound Closure

Use the appropriate method for surgical closure of the incision.

Postoperative Treatment

Postoperative treatment with locking plates does not differ from conventional open reduction internal fixation (ORIF) procedures.

Implant Removal

To remove Locking Screws, use the Mini Hexagonal Screwdriver to first unlock all screws from the plate and then remove the screws completely. Do not use the Forward Captive Screwdrivers for removal.

Instruments and Implants

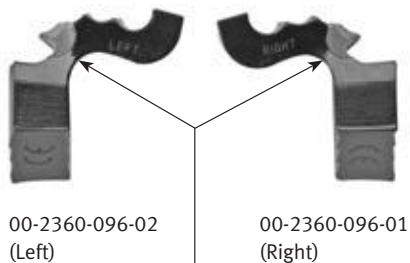

00-2360-096-02
(Left)

00-2360-096-01
(Right)



Metaphyseal Jig



Distal Radial Volar Lateral Column Plate

00-2358-014-XX
(Left)

00-2358-013-XX
(Right)



2.0mm/1.8mm Standard Cannula
00-2360-022-18

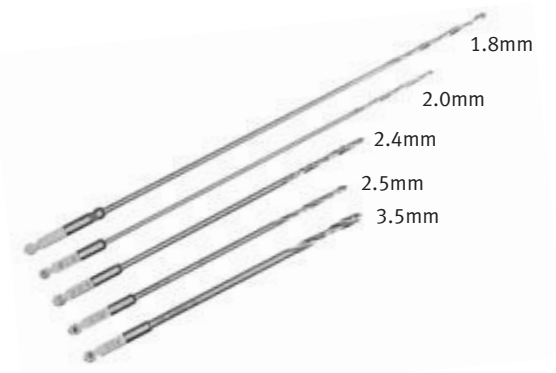

1.8mm Standard Drill
00-2360-155-18

2.0mm QC Drill Bit
00-2360-175-20

2.4mm QC Drill Bit
(For Gliding Hole Technique Only)
00-4806-100-24

2.5mm Drill Bit, 110mm
00-4806-110-25

3.5mm Drill Bit, 110mm
(For Gliding Hole Technique Only)
00-4806-110-35



Mini Handle QC
00-4811-015-00



2.4mm/1.8mm Locking Screw
Depth Gauge
00-2360-042-24



Small Depth Gauge
00-4810-002-01



T-Handle, QC
00-4811-035-00



3.5mm Tap
00-4811-110-35



2.4mm Locking Screw Tap
00-2360-052-24

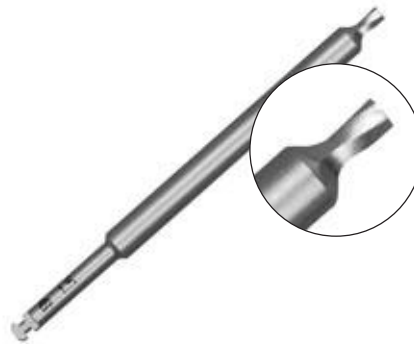

1.5mm Hex Screwdriver Shaft,
Forward Captive
(For screw insertion only)
00-2360-062-15

2.5mm Hex Screwdriver Shaft,
Forward Captive
(For screw insertion only)
00-2360-062-25

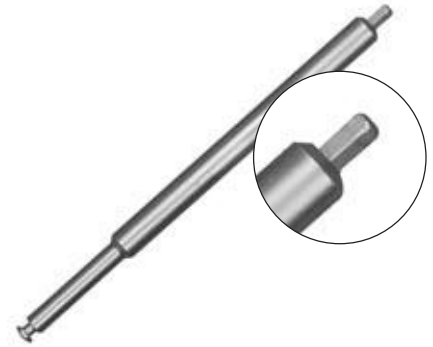

Mini Hex Screwdriver Shaft
00-4812-015-01



1.8mm
Locking
Peg



2.4mm
Locking
Screw



2.4mm
Conical
Screw

1.8mm Locking Pegs
00-2359-XXX-18

2.4mm Locking Screws
00-2359-XXX-24

2.4mm Conical Screws
00-2359-XXX-25

Ordering Information

Prod. No	Description
00-2360-000-03	2.4mm Locking Instrument Set
00-2358-045-00	Distal Radial Locking Screw and Instrument Case
00-2360-022-18	2.0mm/1.8mm Standard Cannula
00-2360-042-24	2.4mm/1.8mm Locking Screw Depth Gauge
00-2360-052-24	2.4mm Locking Screw Tap
00-2360-062-15	1.5mm Hex Screwdriver, QC, Forward Captive
00-2360-062-25	2.5mm Hex Screwdriver, QC, Forward Captive
00-2360-155-18	1.8mm Standard Drill
00-2360-175-20	2.0mm QC Drill Bit
00-4806-100-24	2.4mm QC Drill Bit (For gliding hole technique only)
00-4808-024-01	2.4mm/1.8mm Double Drill Sleeve
00-4811-015-00	Screwdriver Handle, ZPS Mini, stainless steel
00-4901-012-15	1.25mm Diameter Kwire, Trocar Point One End, 6" long
00-4901-016-15	1.6mm Diameter Kwire, Trocar Point One End, 6" long
00-2348-035-00	3.5mm Dual Compression Drill Guide
00-4806-110-25	2.5mm Drill Bit, 110mm
00-4806-110-35	3.5mm Drill Bit, 110mm (For gliding hole technique only)
00-4808-035-01	3.5mm/2.5mm Double Drill Sleeve
00-4808-035-02	3.5mm/2.5mm Drill Sleeve
00-4810-002-01	Small Depth Gauge
00-4811-035-00	T-Handle, QC
00-4811-110-35	3.5mm Tap
00-4812-001-00	Screw Forceps
00-4812-015-01	Mini Hex Screwdriver Shaft
00-4812-015-05	Mini Holding Sleeve
00-4812-035-00	Small Hexagonal Screwdriver, 2.5mm Hex
00-4812-035-05	Small Holding Sleeve
00-4819-051-00	Pin Cutter (Used to cut 1.8mm Locking Pegs)

Prod. No	Description
00-2360-000-23	Distal Radial Standard Jig Set
00-2360-096-01	Volar Lateral Column Jig, Right
00-2360-096-02	Volar Lateral Column Jig, Left
00-2358-025-00	Distal Radial Plate and Jig Case

Ordering Information

Prod. No	Description
00-2358-000-03	Distal Radial Locking Plate Set
00-2358-013-02	Distal Radial Volar Lateral Column Locking Plate, 2 Hole, 30mm Lng, Right
00-2358-013-03	Distal Radial Volar Lateral Column Locking Plate, 3 Hole, 39mm Lng, Right
00-2358-013-04	Distal Radial Volar Lateral Column Locking Plate, 4 Hole, 52mm Lng, Right
00-2358-013-06	Distal Radial Volar Lateral Column Locking Plate, 6 Hole, 74mm Lng, Right
00-2358-013-08	Distal Radial Volar Lateral Column Locking Plate, 8 Hole, 96mm Lng, Right
00-2358-013-10	Distal Radial Volar Lateral Column Locking Plate, 10 Hole, 118mm Lng, Right
00-2358-013-12	Distal Radial Volar Lateral Column Locking Plate, 12 Hole, 140mm Lng, Right
00-2358-014-02	Distal Radial Volar Lateral Column Locking Plate, 2 Hole, 30mm Lng, Left
00-2358-014-03	Distal Radial Volar Lateral Column Locking Plate, 3 Hole, 39mm Lng, Left
00-2358-014-04	Distal Radial Volar Lateral Column Locking Plate, 4 Hole, 52mm Lng, Left
00-2358-014-06	Distal Radial Volar Lateral Column Locking Plate, 6 Hole, 74mm Lng, Left
00-2358-014-08	Distal Radial Volar Lateral Column Locking Plate, 8 Hole, 96mm Lng, Left
00-2358-014-10	Distal Radial Volar Lateral Column Locking Plate, 10 Hole, 118mm Lng, Left
00-2358-014-12	Distal Radial Volar Lateral Column Locking Plate, 12 Hole, 140mm Lng, Left

Prod. No.	Description
00-2359-000-03	2.4mm Locking Screw Set
00-2359-008-24	2.4mm Locking Screw 8mm Lng
00-2359-010-24	2.4mm Locking Screw 10mm Lng
00-2359-012-24	2.4mm Locking Screw 12mm Lng
00-2359-014-24	2.4mm Locking Screw 14mm Lng
00-2359-016-24	2.4mm Locking Screw 16mm Lng
00-2359-018-24	2.4mm Locking Screw 18mm Lng
00-2359-020-24	2.4mm Locking Screw 20mm Lng
00-2359-022-24	2.4mm Locking Screw 22mm Lng
00-2359-024-24	2.4mm Locking Screw 24mm Lng
00-2359-026-24	2.4mm Locking Screw 26mm Lng
00-2359-028-24	2.4mm Locking Screw 28mm Lng
00-2359-030-24	2.4mm Locking Screw 30mm Lng
00-2359-032-24	2.4mm Locking Screw 32mm Lng
00-2359-034-24	2.4mm Locking Screw 34mm Lng
00-2359-036-24	2.4mm Locking Screw 36mm Lng
00-2359-038-24	2.4mm Locking Screw 38mm Lng
00-2359-040-24	2.4mm Locking Screw 40mm Lng
00-2359-018-18	1.8mm Locking Peg 18mm Lng
00-2359-020-18	1.8mm Locking Peg 20mm Lng
00-2359-022-18	1.8mm Locking Peg 22mm Lng

Prod. No.	Description
00-2359-024-18	1.8mm Locking Peg 24mm Lng
00-2359-026-18	1.8mm Locking Peg 26mm Lng
00-2359-028-18	1.8mm Locking Peg 28mm Lng
00-2359-030-18	1.8mm Locking Peg 30mm Lng
00-2359-040-18	1.8mm Locking Peg 40mm Lng
00-2359-008-25	2.4mm Conical Screw 8mm Lng
00-2359-010-25	2.4mm Conical Screw 10mm Lng
00-2359-012-25	2.4mm Conical Screw 12mm Lng
00-2359-014-25	2.4mm Conical Screw 14mm Lng
00-2359-016-25	2.4mm Conical Screw 16mm Lng
00-2359-018-25	2.4mm Conical Screw 18mm Lng
00-2359-020-25	2.4mm Conical Screw 20mm Lng
00-2359-022-25	2.4mm Conical Screw 22mm Lng
00-2359-024-25	2.4mm Conical Screw 24mm Lng
00-2359-026-25	2.4mm Conical Screw 26mm Lng
00-2359-028-25	2.4mm Conical Screw 28mm Lng
00-2359-030-25	2.4mm Conical Screw 30mm Lng
00-2359-032-25	2.4mm Conical Screw 32mm Lng
00-2359-034-25	2.4mm Conical Screw 34mm Lng
00-2359-036-25	2.4mm Conical Screw 36mm Lng
00-2359-038-25	2.4mm Conical Screw 38mm Lng
00-2359-040-25	2.4mm Conical Screw 40mm Lng
00-2348-008-35	3.5mm Cortical Self-Tapping (2.7mm Head) Screw 8mm Lng
00-2348-010-35	3.5mm Cortical Self-Tapping (2.7mm Head) Screw 10mm Lng
00-2348-012-35	3.5mm Cortical Self-Tapping (2.7mm Head) Screw 12mm Lng
00-2348-014-35	3.5mm Cortical Self-Tapping (2.7mm Head) Screw 14mm Lng
00-2348-016-35	3.5mm Cortical Self-Tapping (2.7mm Head) Screw 16mm Lng
00-2348-018-35	3.5mm Cortical Self-Tapping (2.7mm Head) Screw 18mm Lng
00-2348-020-35	3.5mm Cortical Self-Tapping (2.7mm Head) Screw 20mm Lng
00-2348-022-35	3.5mm Cortical Self-Tapping (2.7mm Head) Screw 22mm Lng
00-2348-024-35	3.5mm Cortical Self-Tapping (2.7mm Head) Screw 24mm Lng
00-2348-026-35	3.5mm Cortical Self-Tapping (2.7mm Head) Screw 26mm Lng
00-2348-028-35	3.5mm Cortical Self-Tapping (2.7mm Head) Screw 28mm Lng
00-2348-030-35	3.5mm Cortical Self-Tapping (2.7mm Head) Screw 30mm Lng
00-2348-032-35	3.5mm Cortical Self-Tapping (2.7mm Head) Screw 32mm Lng
00-2348-034-35	3.5mm Cortical Self-Tapping (2.7mm Head) Screw 34mm Lng
00-2348-036-35	3.5mm Cortical Self-Tapping (2.7mm Head) Screw 36mm Lng
00-2348-038-35	3.5mm Cortical Self-Tapping (2.7mm Head) Screw 38mm Lng
00-2348-040-35	3.5mm Cortical Self-Tapping (2.7mm Head) Screw 40mm Lng



Please refer to the package insert for complete product information, including contraindications, warnings, precautions, and adverse effects.

Contact your Zimmer representative or visit us at www.zimmer.com

