

Surgical
Technique

*Herbert Mini
Bone Screw*

Free-Hand Insertion

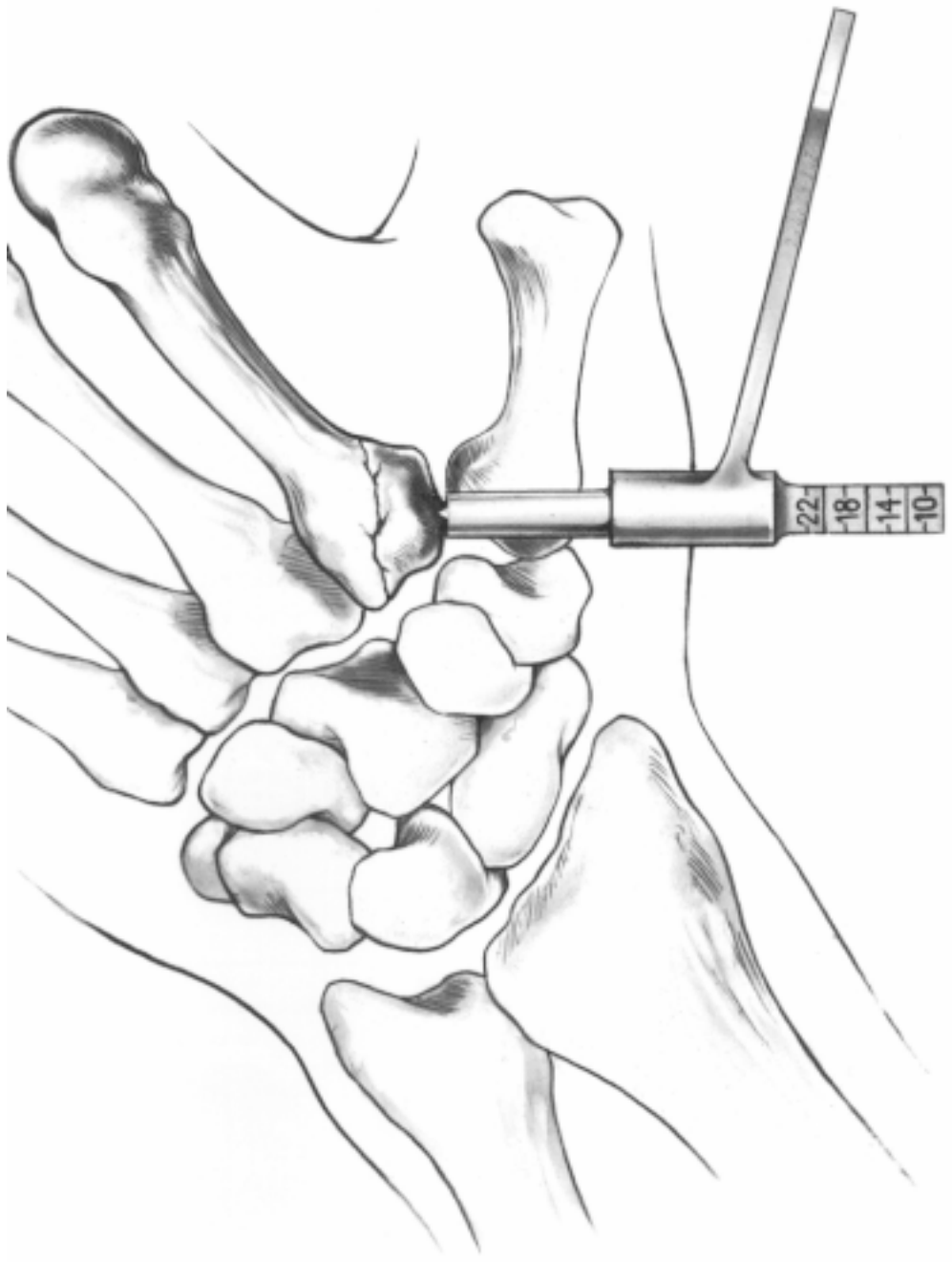

Open Procedure with Free-Hand Guide

The free-hand technique must be used with the *Herbert Mini Bone Screw*. This technique is appropriate for very small proximal pole fractures of the scaphoid, as well as fixation of other small intra-articular fractures, osteochondral fragments, and small joint fusions.*

The Free-Hand Guide is used to direct the instruments and screw.

It is imperative that the two fragments are precompressed firmly together during free-hand insertion of the screw. This can usually be achieved by applying manual pressure on the handle of the Guide only using the Bone-Holding Forceps as a fracture reduction clamp. Use temporary K-wires to maintain the reduction.

Surgical Procedure

Step 1 — Apply Free-Hand Guide

Once the fracture is reduced, apply the Free-Hand Guide to the bone (Figure 3-1). Whenever possible, place one or two accessory wires through the alignment holes on the Free-Hand Guide to further secure the bone fragments (Figure 3-1 Inset). This will prevent any displacement or fragment rotation during the procedure. Use of these guide holes will ensure that the K-wires are parallel. They can accept a stabilization K-wire up to 1.1mm in diameter.

Step 2 — Drill the Pilot Hole

Insert the Pilot Drill into the barrel of the Free-Hand Guide. Turn the handle and advance the Drill until it bottoms out (Figure 3-2). Removing the Drill in a clockwise direction will remove bone fragments and facilitate further instrumentation.

Step 3 — Drill the Main Hole

Insert the Main Drill into the Free-Hand Guide to the appropriate depth as read on the calibrated barrel (Figure 3-3). Turn the Drill in a clockwise direction to maximize efficiency in cutting and chip removal. If the bone is hard, withdraw the Drill periodically to remove bone fragments.

*To guard against bending or breakage of the *Herbert Mini Screw*, excessive torque or bending forces should be avoided.

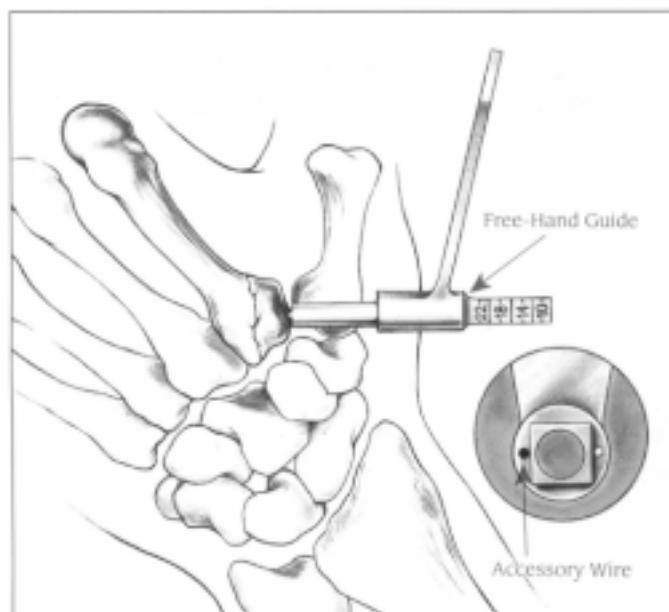

FIGURE 3-1 Apply manual pressure to firmly hold the anatomic reduction of the fracture fragment. Inset shows holes used to place parallel accessory fixation wires through the Guide

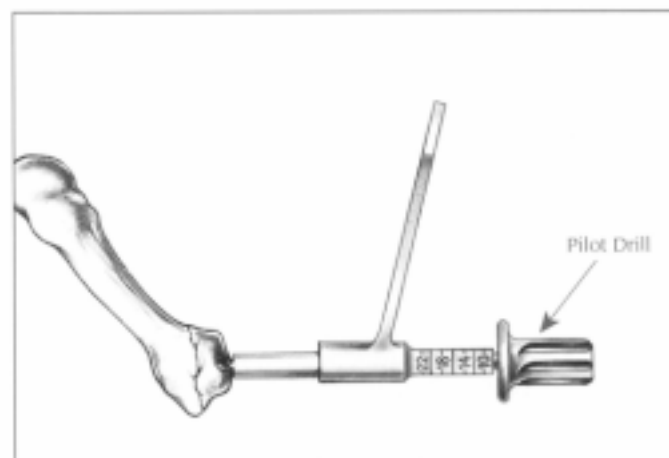

FIGURE 3-2 Drill the pilot hole through the proximal cortex

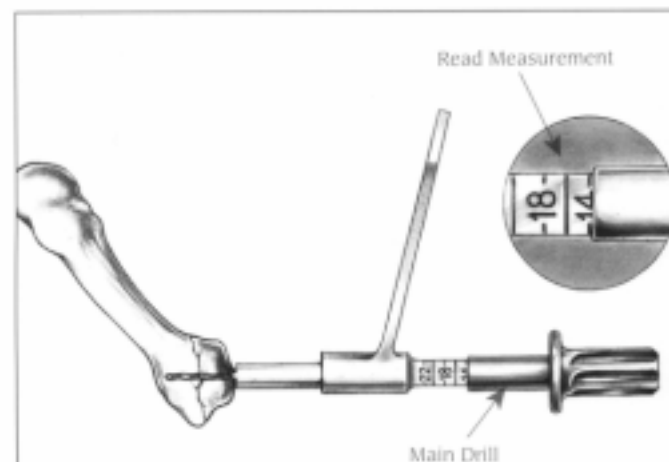

FIGURE 3-3 Drill the main hole for the core diameter of the leading threads and the shaft

Step 4 — Tap

Tap the leading screw threads. Insert the Tap using a clockwise turning movement until the appropriate depth is read on the calibrated barrel (Figure 3-4). Remove the Tap by turning in a counter-clockwise direction. It is essential that the Tap be inserted to the full drill depth, otherwise the compressive action of the screw may be lost.

Step 5 — Select the Appropriate Screw

Select the appropriate length screw, lifting it out of the sterilization rack with the Screwdriver (Figure 3-5). Note that the calibrated barrel is designed to countersink the screw end(s) 1mm to 2mm below the cortical surfaces. If maximum bicortical fixation is desired, select a bone screw 2mm longer than the calibration read when drilling. Check the length of the screw against the calibrated scale adjacent to the screw rack (Figure 3-5 Inset). (Packaged bone screws are presterilized.)

Step 6 — Insert Screw

Insert the screw and Screwdriver through the Free-Hand Guide (Figure 3-6), turning the Screwdriver clockwise. As the trailing thread enters the bone, increased resistance will be felt and further reduction at the fracture site will be visible. Remove the Free-Hand Guide.

To apply additional reduction and/or compression at the fracture site, or to completely bury the screw head, rotate the screw one or more revolutions with the Screwdriver.

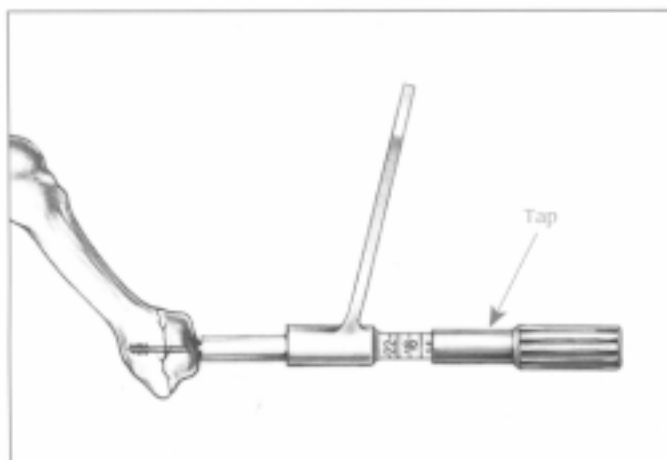

FIGURE 3-4 Tap the full depth of the Main Drill for the leading threads and the shaft

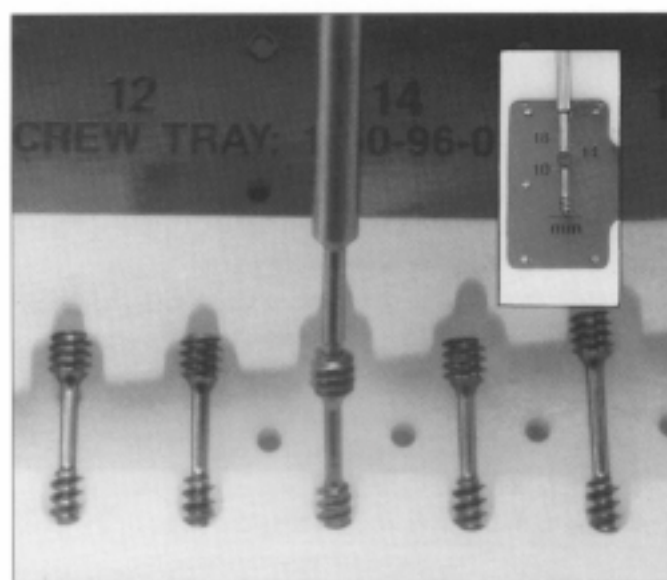

FIGURE 3-5 Lift the Herbert Mini Screw from rack, Screwdriver fully engaged in hexagonal socket

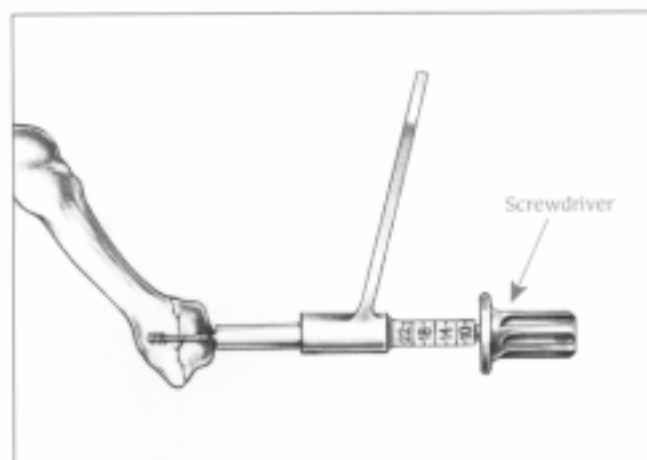
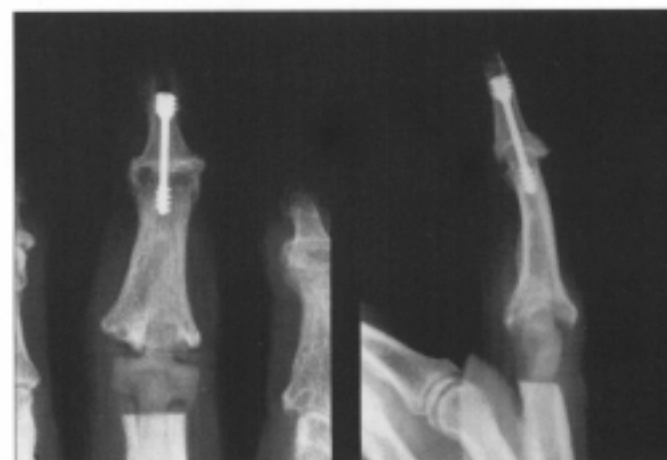

FIGURE 3-6 Implant the Herbert Mini Bone Screw through the Free-Hand Guide (Bennett's Fracture fixation)



Postoperative x ray of Herbert Mini Bone Screw used to fuse the DIP joint of a little finger

Technique Variations

Cortical Bone Fixation

(For the *Herbert* and *Herbert Mini* Bone Screws)

The *Herbert* Bone Screw was designed specifically for fixation of cancellous bone fragments and its use in cortical bone is not normally recommended. However, on certain occasions it may be desirable to insert the screw through a hard cortical surface, e.g.:

- ✓ Interphalangeal fusion of digits
- ✓ Fixation of oblique metatarsal osteotomies
- ✓ Fixation of very small or delicate bones

1. In very small or delicate bones, cortical bone may provide better fixation than cancellous. The resistance to pull-out and the capability of applying and maintaining rigid fixation is greater. It is desirable to capture cortical bone at both ends of the bone screw to optimize the reductive capabilities of these *Herbert Mini* Bone Screws. The surgeon should drill and tap for the leading threads through the opposite cortex. This will prevent the bone screw from accidentally stripping the cancellous thread purchase within the inner cortical wall. (Stripping the threads with excessive torque could result in distraction of the fracture fragment which had been previously reduced.) However, it is sometimes more difficult to fully seat the self-reducing and self-compressing *Herbert* and *Herbert Mini* Bone Screws bicortically in this type of bone. When using the *Herbert Mini* Bone Screws, this difficulty occurs when the cortices on both sides are greater than 5mm in thickness.

2. For the standard *Herbert* Screw, use the 3.2mm *Herbert* Power Drill or the 2.7mm or 3.2mm *ECT* Drill. This facilitates entry of the trailing thread and prevents it from splitting the cortex.

For use of the *Herbert Mini* Screw in dense cortical bone, the 2mm 1154-81 *Herbert* Power Drill should be used in place of the 1.5mm *Herbert Mini* System Leading Drill. Drill completely through both cortices. **NOTE: These alternative Drills do not fit into the *Mini* System's Free-Hand Guide.** Tap



FIGURE 3-7 Showing correct method of drilling through cortical bone (power may be preferred) with the Free-Hand Guide located in a "hollow" created in the cortex with a rongeur or large drill

completely through both cortices before inserting the screw. If the bone is too hard for the points of the drill guide to engage, gouge out a small hollow to assist in location of the guide (Figure 3-7). Then drill and tap the medulla in the normal fashion. Take care to ensure that the leading end of the screw does not abut the opposite cortex.

3. **CAUTION:** If complete reduction is attained prior to insertion of the bone screw, it is possible to generate torques which will cause failure of the tip of the Screwdriver prior to fully seating the bone screw. To avoid instrument breakage, one of two steps must be taken:
 - A. Accept that the trailing threads of the bone screw will not fully seat. Closely monitor the hex tip of the Screwdriver. Be sure to stop torquing the handle when you feel the hex tip begin to slip or deform.
 - B. Counterbore the proximal cortex with the *Herbert* 3.2mm diameter Power Pilot Drill for a depth of 2mm to 3mm.
4. When attempting to maximize cortical fixation on both ends of the bone screw, a screw 2mm longer than indicated by the guide calibration should then be used to ensure that the leading threads are purchased in the cortical bone.

Warnings

1. Failure to maintain fracture reduction, failure of the Screwdriver tip, or failure of the bone screw itself could occur if this varied technique is not utilized in situations where bicortical purchase is desired.
2. The Screwdriver tip must always be fully inserted within the screw socket to transmit the load properly and prevent stripping or rounding of the corners of the hexagonal tip of the driver.

For further details on these and other techniques, please refer to the appropriate literature mentioned in the "Suggested Reading" and "References" listings on page 36.



zimmer